

PAGE[®]

PACE MULTI ARM-EVAC II[®]

FUME EXTRACTION SYSTEMS

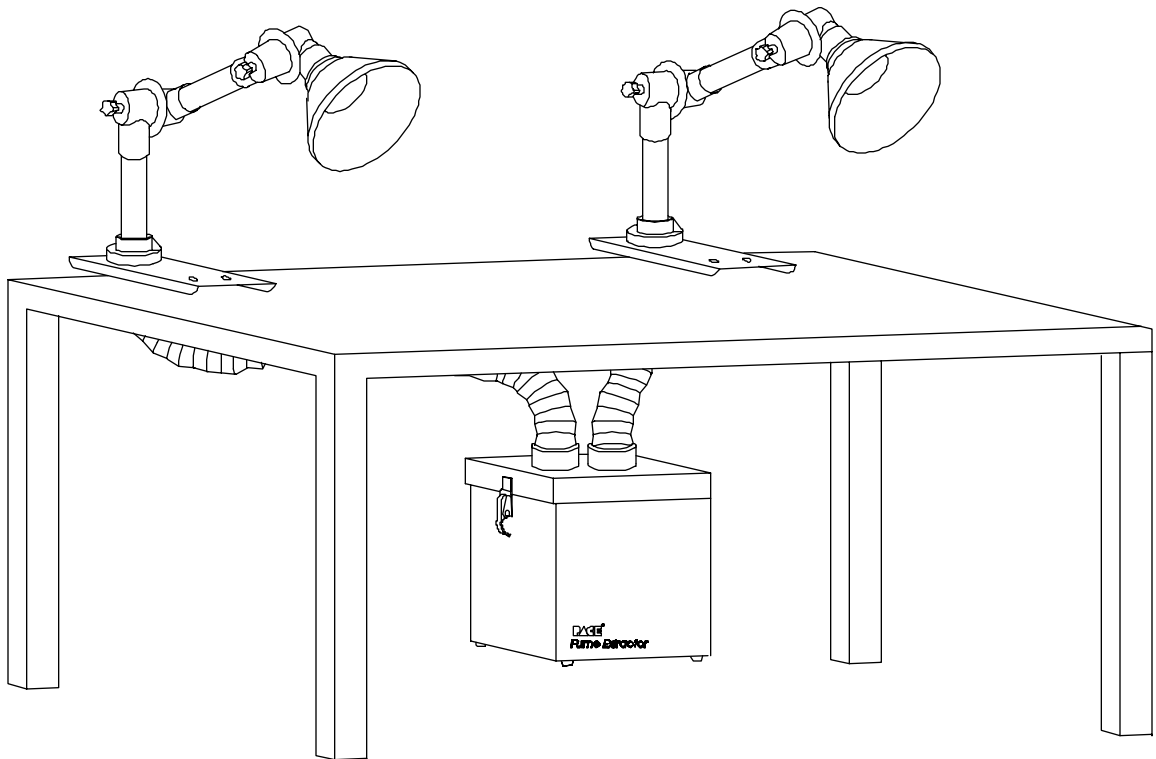

OPERATION &

MAINTENANCE

MANUAL

MANUAL NO. 8881-0945

REV. E

JULY 1997

Warning

Read the safety and applications information section in the operation and maintenance manual thoroughly *before* installing and using your fume extraction system.



PACE retains the right to make changes to specifications contained herein at any time, without notice.

Contact your local authorized PACE Distributor or PACE to obtain the latest specifications.

The following are registered trademarks and/or servicemarks of PACE Incorporated, Laurel Maryland U.S.A. and may only be used to identify genuine PACE products or services:

AdapTip, Arm-Evac, Cir-Kit, ComForm I, ConducTweez, CRAFT, Dual Path, Flo-D-Sodr, FuseSet, HandiPik, HotSpot, LapFlo, MBT, Micro Portable, MicroChine, MiniChine, Mini-Wave, PACE, Pacenter, Ped-A-Vac, PETS, Pik-Vac, PRC, PRINT, Pro-Evac, Redi-Rak, ResisTweez, SensaTemp, SMR, Snap-Vac, Sodr-Pen, Sodr-X-Tractor, SR-3, SR-4, ST, StripTweez, SwaPlater, ThermoBand, Thermo-Drive, ThermoJet, ThermoPart, ThermoPik, ThermoTweez, Tip-Evac, VisiFilter.

The following are trademarks and/or servicemarks of PACE Incorporated, Laurel Maryland U.S.A. and may only be used to identify genuine PACE products or services:

Auto Off, Cubby-Vac, Datastore, Dust Evac, EKO, Lab Evac, MicroSpin, PaceLink, PaceNet, Pik & Paste, Prep-Set, Pulse Plate, Spa-Kleen, ThermoBond, TinSpin, TweezPik, Uni-Frame, V-A-N, Ventur-Evac.



Since 1958, PACE Incorporated has provided advanced technology training in all aspects of hand soldering, rework and repair.

Additional copies of this manual or other PACE literature may be obtained from:

PACE Europe Ltd.
Sherbourne House
Sherbourne Drive
Tilbrook
Milton Keynes

MK7 8HX Tel: (44) 01908 277666
England Fax: (44) 01908 277777

PACE Incorporated
Sales Administration
9893 Brewers Court
Laurel MD 20723-1990
USA

Tel: (301) 490-9860
Fax: (301) 498-3252

©1996 PACE Incorporated, Laurel MD. All rights reserved. Printed in the U.S.A.

TABLE OF CONTENTS

| TITLE | PAGE |
|--|-------------|
| General Information | 1 |
| Use of this Manual | 1 |
| Introduction | 1 |
| Specifications | 1 |
| Safety and Application Information | 5 |
| Installation | 8 |
| Operation | 16 |
| Fuses | 16 |
| Maintenance | 17 |
| Filter Replacement | 17 |
| Motor | 18 |
| Replacement Filters | 18 |
| Accessories | 19 |
| Multi Arm-Evac II Accessories | 19 |
| Filter Options | 22 |
| Articulated Arms and Accessories | 23 |
| Endpieces and Mounting Brackets | 23 |
| Warranty | 25 |

TABLES & FIGURES

TABLES

| | |
|---|----|
| Table 1: Central Filtration Unit Specifications | 2 |
| Table 2: Replacement Filters | 18 |

FIGURE

| | |
|--|----|
| Figure 1: Multi Arm-Evac II Dimensions | 3 |
| Figure 2: Multi Arm-Evac II Parts Identification | 4 |
| Figure 3: Expansion Kit Installation | 18 |
| Figure 4: Multi Arm-Evac II - Articulated Arms | 23 |
| Figure 5: Endpieces and Mounting Brackets | 23 |

GENERAL INFORMATION

USE OF THIS MANUAL

This manual will provide the user with the basic knowledge to properly operate and maintain the PACE Multi Arm-Evac II Fume Extraction System. PACE STRONGLY RECOMMENDS THAT THE USER READ AND FULLY UNDERSTAND THIS MANUAL PRIOR TO USE OF THE SYSTEM. If you encounter any difficulty operating your system or have any questions, call your local authorized PACE dealer or contact PACE Applications Engineering directly at the United Kingdom Office at Tel. (44) 01908 277666, Fax (44) 01908 277777, or PACE Product Management at the U.S. Office at Tel. (301) 490-9860, Fax (301) 604-8782.

INTRODUCTION

The PACE Multi Arm-Evac II Fume Extraction System represents the latest technology in fume extraction. It features a heavy-duty, maintenance-free brushless motor along with a filtration process that includes a pre-filter for coarse particle removal, and a High Efficiency Particulate Air (HEPA)/Gas Filter cartridge. The HEPA/Gas Filter is ideal for use in applications where high efficiency particulate removal is required with the additional benefit of a gas media blend to neutralize and adsorb noxious gases. Optional filters are also available. See Page 22.

PACE Multi Arm-Evac II Fume Extraction Systems use specially designed extraction accessories that can be conveniently mounted on any workbench or tabletop. The PACE Multi Arm-Evac II is designed to extract fumes from one or two work stations.

SPECIFICATIONS

Environmental

| | |
|--------------------------------|--|
| Ambient Operating Temperature: | 0°C to 50°C (32°F to 122°F) |
| Storage Temperature: | -40°C to 125°C (-40°F to 257°F) |
| Ambient Operating Humidity: | 90% relative humidity maximum non-condensing |
| Storage Humidity: | 90% relative humidity maximum non-condensing |

GENERAL INFORMATION

SPECIFICATIONS

| MULTI ARM-EVAC II SPECIFICATIONS | | |
|---|---|----------------------|
| Part Number | 8888-0815 | 8888-0825 |
| Power Requirements | 230V, 50Hz 1.38 amps | 110V, 60Hz 3 amps |
| Size | 280mm x 280mm x 395mm (11"x11"x15.5") | |
| Weight | 14.0kg (31 lbs) | |
| Flow Rate (Dual Inlet) | 333 m ³ /h (196 cfm) [166.5 m ³ /h (98 cfm) per inlet] | |
| Flow Rate (Single Inlet) | 280 m ³ /h (165 cfm) | |
| Motor Type | Single Stage Centrifugal Pump | |
| Pre-Filter Type | Multistage Polyester Media, Rated 86% Arrestance | |
| Pre-Filter Dimensions | 254mm x 254mm x 25mm (10" x 10" x 1") P/N 8883-0111-P10 | |
| Combo HEPA/Gas Filter Cartridge Dimensions | 254mm x 254mm x 178mm (10" x 10" x 7") P/N 8883-0931 | |
| HEPA Filter Rating | 99.97% Overall Efficiency | |
| HEPA Filter Media Surface | 2.8m ² (30 sq.ft.) | |
| Gas Filter | Composite of Chemisorptive and Adsorptive Medias | |
| Optional Foam Filter Cartridge Dimensions | 254mm x 254mm x 178mm (10" x 10" x 7") P/N 8883-0871 | |
| Foam Filter Rating | 95% Overall Efficiency | |
| Inlets | Two 75mm (3") | |
| Ducting Style | 75mm (3") flexible hose | |
| Housing | 18 gauge steel | |
| Noise Level at 2 meters (6.5') | 59 dBA | |

Table 1: Central Filtration Unit Specifications

GENERAL INFORMATION

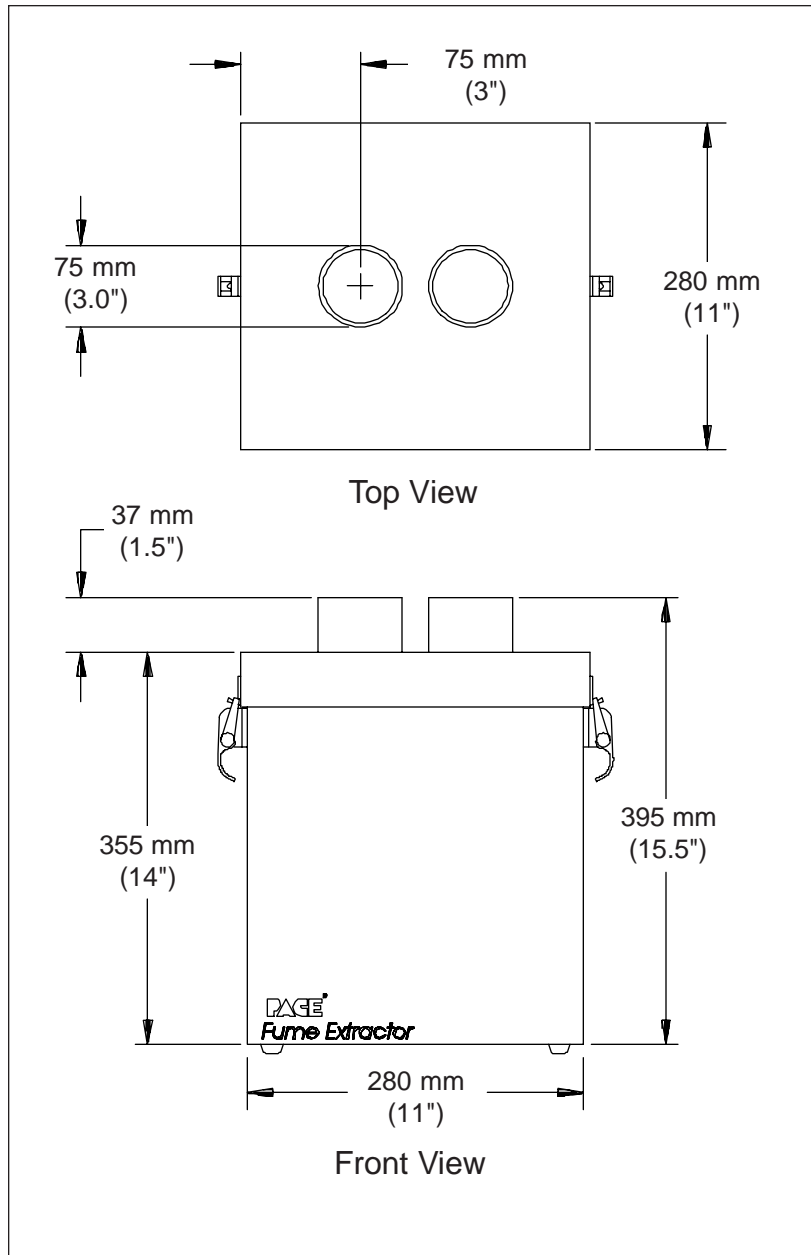

Figure 1: PACE Multi Arm-Evac II Dimensions

GENERAL INFORMATION

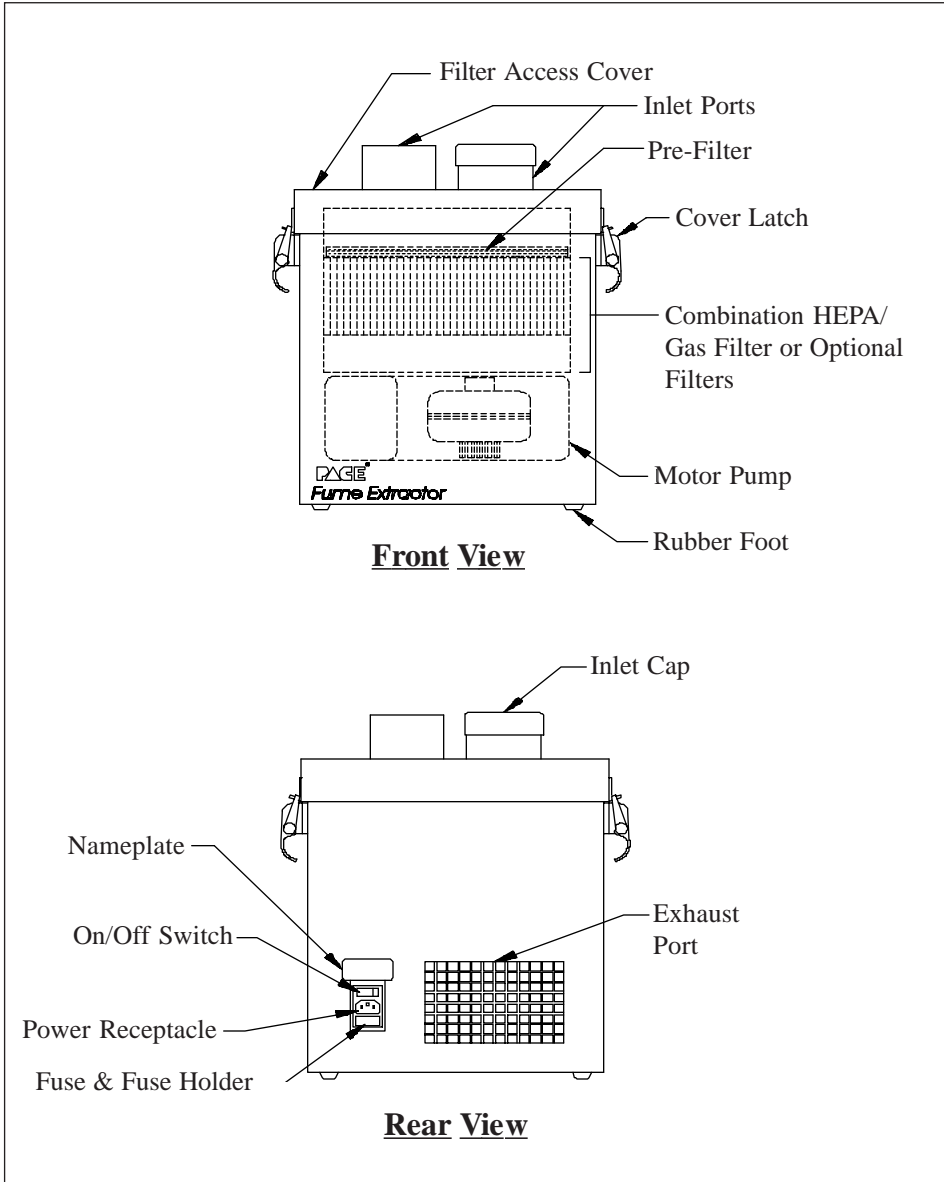

Figure 2: PACE Multi Arm-Evac II Parts Identification

SAFETY AND APPLICATIONS INFORMATION

PACE Fume Extraction systems are designed to reduce the level of harmful contaminants from the work environment and to assist in the achievement of recommended health and safety requirements for local exhaust ventilation and contaminant removal. Be sure to follow all Application and Maintenance guidelines contained herein and precautions contained in other relevant product safety literature (i.e., Material Safety Data Sheets) provided with the substances and equipment producing the fumes to be extracted.

DISCLAIMER

PACE hereby disclaims all responsibility for any personal injury, property damage, fine, citation or penalty imposed by any government or private entity which results from any use, misuse or mis-application of this product, failure of the user to regularly maintain the product according to the recommended guidelines, or failure to adequately monitor fume extraction exhaust air and the ambient workplace air for the presence of harmful levels of gases, fumes and particulates.

Compliance with all applicable environmental and personnel safety regulations is the sole responsibility of the user and adequate self-monitoring of exhaust air released into the atmosphere or the workplace as well as monitoring of the ambient workplace air is strongly recommended.

Warning

FAILURE TO COMPLY WITH THE APPLICATION AND MAINTENANCE GUIDELINES, FILTER REPLACEMENT SCHEDULES, MONITORING RECOMMENDATIONS AND SAFETY GUIDELINES CONTAINED HEREIN AND IN OTHER RELEVANT PRODUCT SAFETY LITERATURE (I.E., MATERIAL SAFETY DATA SHEETS) PROVIDED WITH THE SUBSTANCES AND EQUIPMENT PRODUCING THE FUMES TO BE EXTRACTED COULD RESULT IN RISK OF SERIOUS INJURY, FIRE OR EXPLOSION.

To insure continued effective performance, the following guidelines must be followed.

General Purpose Filter Cartridge

The Multi Arm-Evac II is equipped with the General Purpose Filter Cartridge which has been designed to capture particulates and noxious gases and odors that are present in the air being filtered. Over time, the HEPA filter will gradually become clogged, impeding air flow through the system, and the capacity of the gas filter will be reached, reducing its ability to continue to neutralize and adsorb noxious gases and odors.

General Purpose Filter Cartridges **must be replaced at regular intervals** to ensure that the fume extraction system is operating effectively. These intervals will vary depending on the type of work being performed, the level of use, and the amount and composition of airborne contaminants produced.

SAFETY AND APPLICATIONS INFORMATION

Caution

To ensure the highest level of performance, use only PACE replacement filters in your Multi Arm-Evac II.

The exhaust air stream from the central filtration unit as well as the ambient air in the workplace should be monitored with appropriate and adequate measuring/detection devices to assure compliance with all applicable Health and Safety regulations.

Flammable vapors and gases (i.e. Isopropyl Alcohol) are removed by and accumulate in the gas portion of the General Purpose Filter Cartridge presenting a potential fire hazard. Therefore, the user must exercise appropriate precautions when extracting such fumes or when handling and disposing of filters containing such flammable substances. Follow *all fire safety and personnel protection guidelines* contained in the Material Safety Data Sheet (MSDS) for the substance(s) producing the extracted vapors and gases (fumes).

Danger

PACE FUME EXTRACTORS ARE NOT INTENDED TO BE USED AS A SUBSTITUTE FOR DEVICES SUCH AS PERSONAL PROTECTIVE RESPIRATORS WHICH ARE DESIGNED TO REMOVE POORLY ADSORBED SUBSTANCES INCLUDING CARBON MONOXIDE, METHANE, HYDROGEN, ACETYLENE AND OTHER GASES. RISK OF SERIOUS INJURY OR DEATH, FIRE OR EXPLOSION MAY RESULT FROM IMPROPER USE. IF IN DOUBT, CONSULT WITH YOUR INDUSTRIAL HYGIENIST OR PACE.

When disposing of used filters, extreme care must be taken to comply with *all* applicable environmental regulations. Carefully consult the MSDS supplied with the material(s) producing the fume. If in doubt, check with your local Environmental Authority.

Extreme care must be exercised when disposing of a used General Purpose Filter Cartridge containing potentially hazardous substances. When disposing of filters, appropriate and adequate personal protective equipment (i.e. gloves, respirators, plastic containment bags, etc.) must be used when hazardous substances such as asbestos, lead, radioactive or biohazard materials may be present. Consult the Material Safety Data Sheet (MSDS) of the materials generating the extracted fume.

SAFETY AND APPLICATIONS INFORMATION

Danger

NEVER USE PACE FUME EXTRACTION SYSTEMS TO EXTRACT FUMES FROM HIGHLY FLAMMABLE LIQUIDS AND GASES SUCH AS ETHER, GASOLINE (PETROL) AND OTHERS. RISK OF SERIOUS INJURY, DEATH, FIRE OR EXPLOSION MAY RESULT.

CERTAIN AIRBORNE CONTAMINANTS SUCH AS METHYL ETHYL KETONE, CYCLOHEXONE, OZONE AND OTHERS, WHEN CONTACTED WITH ACTIVATED CARBON, CAN UNDERGO OXIDATION, DECOMPOSITION OR POLYMERIZATION RESULTING IN EXOTHERMIC REACTIONS OR HEAT GENERATION. PACE FUME EXTRACTION SYSTEMS MUST NOT BE USED TO EXTRACT FUMES FROM THESE SUBSTANCES.

Warning

Use with inappropriate chemicals or substances, failure to provide regular maintenance or other misuse of your Fume Extraction System may result in contaminated air being recirculated into the work environment.

INSTALLATION

GENERAL

The Multi Arm-Evac II has been designed with maximum installation flexibility in mind. A number of configurations may be used. (See the “Configurations” section.) The following are recommended guidelines for setting up your Multi Arm-Evac II. If you have any specific questions that this section does not cover please consult your PACE Representative or call PACE directly.

1. Placement

There are three major considerations that need to be addressed for proper placement of the central filtration unit.

- **Exhaust Port:** The exhaust port is located on the back of the filtration unit, next to the on/off switch. When positioning the unit, make sure that the exhaust port is *not* blocked or that airflow from the exhaust port is not restricted in any way. Additionally, the on/off switch must be readily accessible.
- **Unit Location:** The filtration unit should be located so that it will not block aisleways or impede normal operating traffic or material handling pathways. It is important to position the unit in such a way that allows for proper clearance to remove the filter access cover and replace the filter as needed.
- **Proximity to the work area:** The filtration unit should be placed as close to the work area as possible. If using a flex hose, it is advantageous to keep the length of flex hose as short as possible. **Do not** kink or create any sharp bends in the flex hose, as this will reduce airflow.

2. Power

The Multi Arm-Evac II will plug into a standard 110 volt or 230 volt electrical outlet, depending on the model you purchased. Be sure the unit you have is rated for the intended power supply.

| |
|----------------|
| Warning |
|----------------|

| |
|---|
| Failure to supply the correct voltage to the unit will result in damage to the motor. |
|---|

3. Filters

Before operating the unit, make sure the filter is correctly positioned. The pre-filter is always on top and the blue side of the prefilter should be facing upward. The direction of airflow is clearly marked on the filter cartridge. Airflow is always in a downward direction for the Multi Arm-Evac II.

4. Inlet Caps

If an inlet port is not connected to a collection device, it must be covered with the inlet cap provided.

5. Accessories

The Multi Arm-Evac II is designed to be used with *one or two* collection accessories (i.e. flex arm, articulated arm, plenum, etc.). When using two collection devices, *any two* may be used together. This provides maximum flexibility in meeting the fume extraction needs in your work environment. See pages 19 through 23.

CONFIGURATIONS

Connecting One or Two Flex Arms

- 1) Slide the narrow end of the Flex Arm (P/N 8886-0365) over one inlet port on the Multi Arm-Evac II.
- 2) Secure the Flex Arm to the inlet of the Multi Arm-Evac II with the Flex Arm clamp (provided).
- 3) Position the Flex Arm for maximum extraction performance.
- 4) If using one Flex Arm, make sure the inlet cap covers the unused inlet.
- 5) Repeat steps 1 through 3 to attach second Flex Arm.

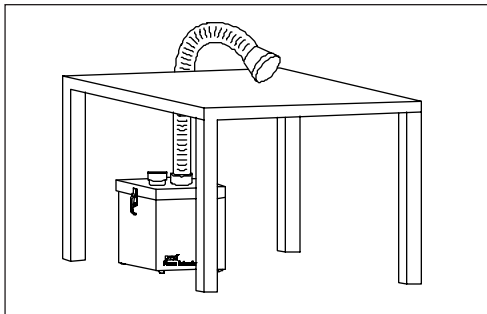

Multi Arm-Evac II fitted with one Flex Arm

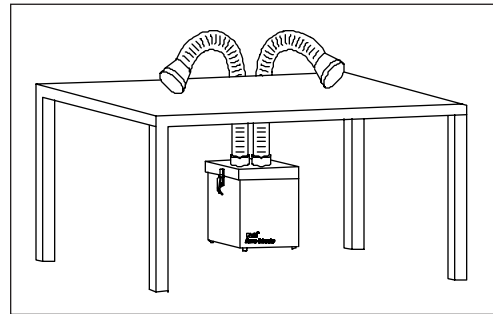

Multi Arm-Evac II fitted with two Flex Arms

NOTE: The Multi Arm-Evac II can be placed on the benchtop or located under a workbench, depending on operator preference.

INSTALLATION

Connecting One or Two Bench Mounted Flex Arms

- 1) To mount the Flex Arm to a bench or tabletop, the optional Bench Mounting Kit (P/N 8886-0363) is required.
- 2) Position the bench mounting bracket on the tabletop and secure it with the two screws provided.
- 3) Slide one end of the flex hose over an inlet port on the Multi Arm-Evac II and secure it with a hose clamp (provided).
- 4) Connect the other end of the flex hose to the bottom of the bench mounting bracket and secure it with the other hose clamp.
- 5) Slide the Flex Arm over the top of the bench mounting bracket and secure it to the bracket with the Flex Arm clamp (provided).
- 6) Position the Flex Arm for maximum extraction performance.
- 7) If using one Flex Arm, make sure the inlet cap covers unused inlet.
- 8) Repeat steps 1 through 6 to attach second arm.

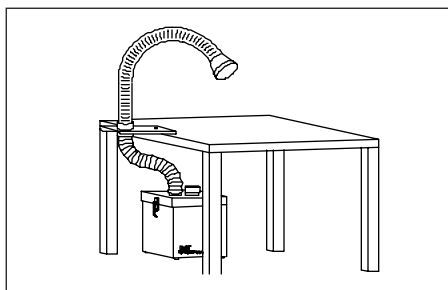

Multi Arm-Evac II fitted with one Flex Arm and Bench Mounting Kit

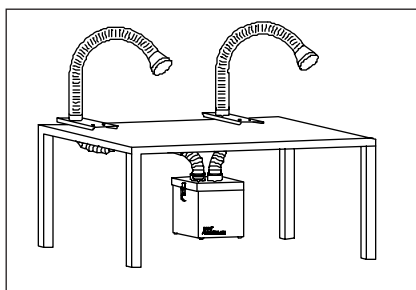

Multi Arm-Evac II fitted with two Flex Arms and Bench Mounting Kits

The Pace Flex Arm (P/N 8886-0365)

The Flex Arm is constructed of a slotted, flexible plastic strip, wound to form the tube length. The flexibility of this construction allows variable arm placement. Frequent adjustments of the arm can cause the arm to lose its ability to stay in position.

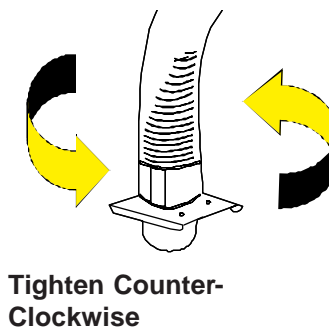
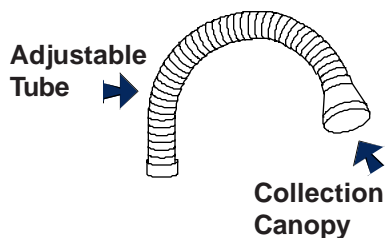

INSTALLATION

To restore the Flex Arm, first compress the tube by pressing down from the top of the arm towards the mounting bracket. Next, tighten the tube by twisting in a **COUNTER-CLOCKWISE** direction. Once tightened, adjust the arm to the desired position. *Do not twist the arm in a clockwise direction!*

Warning

Unwinding the flex arm (twisting in a clockwise direction) may cause the arm windings to separate.

Connecting the PACE Plenum

- 1) Position the Plenum directly behind the main work area. It is important that the entire Plenum is resting on the work surface or table top. Failure to do so will result in insufficient air flow over the work area.
- 2) Install one end of the flexible hose (provided) to the inlet of the Multi Arm-Evac II. Secure the flex hose to the inlet port with the hose clamp (provided).
- 3) Install the other end of the flexible hose to the Plenum. Secure the flex hose to the Plenum with the hose clamp (provided).
- 4) If only one inlet port on the Multi Arm-Evac II is used make sure the unused inlet port is covered with the inlet cap provided.
- 5) Repeat steps 1 through 3 if installing a second Plenum.

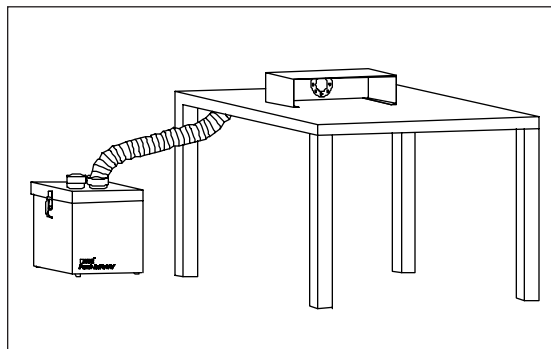

Multi Arm-Evac II fitted with one Plenum

INSTALLATION

Connecting the 45mm (1.75") Static-Safe Metal Flex Arm

- 1) Attach the 45mm (1.75") Static-Safe Metal Flex Arm at a convenient location on the workbench either permanently or with the bench mounting bracket (P/N 8886-1121).

Permanent Mounting: The extraction arm can be permanently mounted to a workbench or tabletop.

- A.) Drill a 50mm (2") diameter hole in the workbench.
- B.) Locate the 45mm (1.75") Static-Safe Metal Flex Arm in the hole and mark the position of the 3 holes in the mounting flange. Remove the 45mm (1.75") Static-Safe Metal Flex Arm and drill the 3 marked areas with a 2mm (3/32") drill. Refit the 45mm (1.75") Static-Safe Metal Flex Arm. Secure the mounting flange to the workbench with the 3 mounting screws (**supplied**).

Portable Bench Mounting: The 45mm (1.75") Static-Safe Metal Flex Arm can be bench mounted with the bench mounting bracket (P/N 8886-1121).

- A.) Open the bench mounting bracket butterfly screw, position the bracket over the edge of the work bench, then tighten the butterfly screw until the bracket is securely mounted on the work bench.
 - B.) Install the 45mm (1.75") Static-Safe Metal Flex Arm on to the bench mounting bracket with the 3 mounting screws (supplied).
- 2) Position the 45mm (1.75") Static-Safe Metal Flex Arm as needed. The Arm can be repositioned simply by grasping the 45mm (1.75") Static-Safe Metal Flex Arm above the fume scoop and moving it to the desired location.
 - 3) Connect the flexible hose (P/N 8886-0299) to the inlet port of the Multi Arm-Evac II and secure it with the hose clamp (provided). Connect the other end of the flex hose, with the reducer, to the inlet of the 45mm (1.75") Static-Safe Metal Flex Arm.
 - 5) If only one inlet port on the Multi Arm-Evac II is used make sure the unused inlet port has its cap in place.
 - 6) Repeat steps 1 through 4 to install additional 45mm (1.75") Static-Safe Metal Flex Arms.

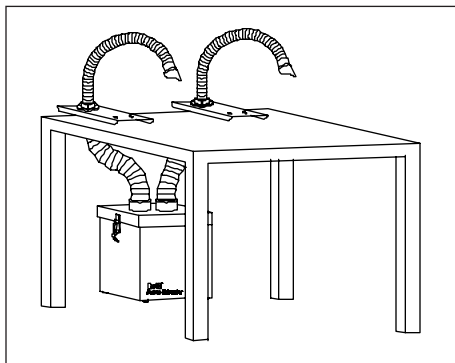

Multi Arm-Evac II fitted with two Metal Flex Arms and mounting accessories

Connecting more than two 45mm (1.75") Static-Safe Metal Flex Arms

To connect up to four Static-Safe Metal Flex Arms (P/N 8886-0369) to a Multi Arm-Evac II, the Metal Flex Arm Expansion Kit (P/N 8882-0692) must be used. The Expansion Kit allows two Metal Flex Arms to be connected to one Multi Arm-Evac II inlet port. Refer to the diagram below when installing three or four 45mm (1.75") static-safe metal flex arms using the Expansion Kit. Remember to keep the flexible hose sections as short as possible to ensure maximum performance.

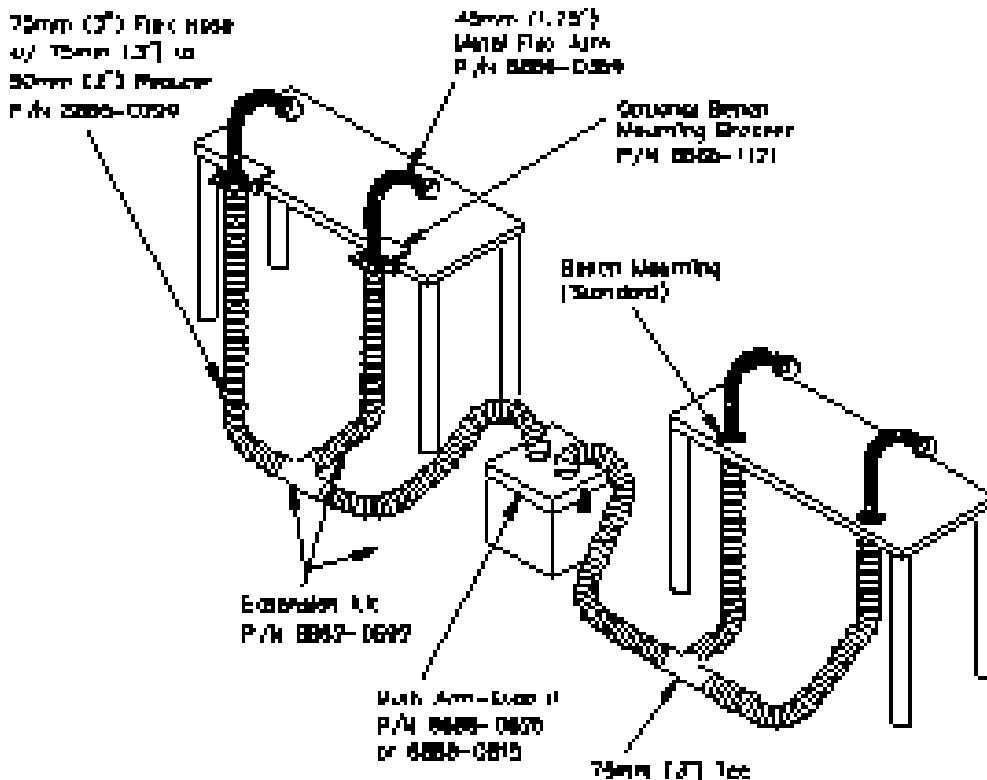

Figure 3: Four Static-Safe Metal Flex Arms connected to a Multi Arm-Evac II using the Expansion Kit

INSTALLATION

Connecting the Articulated Extraction Arm

- 1) Attach the 2 or 3 Section Articulated Arm at a convenient location on the workbench either permanently or with the bench mounting bracket. See Page 23.

Permanent Mounting: The extraction arm can be permanently mounted to a workbench or tabletop.

- A.) Drill a 75mm (3") diameter hole for the 65mm (2.5") Arm or a 50mm (2") diameter hole for the 50mm (2") Arm in the workbench for the vertical pipe section.
- B.) Locate the vertical pipe section in the hole and mark the position of the 3 holes in the mounting flange. Remove the vertical pipe section and drill the 3 marked areas with a 2mm (3/32") drill. Refit the vertical pipe section. Secure the mounting flange to the workbench with the 3 mounting screws (supplied).

Portable Bench Mounting: The extraction arm can be bench mounted with the bench mounting bracket (P/N 8886-0662 for 65mm (2.5") Arm or P/N 8886-1121 for 50mm (2") Arm).

- A.) Open the bench mounting bracket butterfly screw, position the bracket over the edge of the work bench, then tighten the butterfly screw until the bracket is securely mounted on the work bench.
 - B.) Install the vertical pipe section on to the bench mounting bracket with the 3 mounting screws (supplied).
- 2) When attaching the articulated arm to the vertical pipe section, make sure the articulated arm is installed in such a way that the torsion spring points away from the user. The arm should lift up when the thumbscrews are loose. If the arm pulls down, the arm needs to be rotated 180 degrees on the vertical pipe section.
 - 3) Install an endpiece (ordered separately) to the front articulation section, ensuring proper orientation of the nozzle or endpiece for maximum extraction capability. Use the small setscrew to secure the nozzle or endpiece.
 - 4) Connect the flexible hose (P/N 8882-0755 for 65mm (2.5") Arm or P/N 8886-0299 for 50mm (2") Arm) to the inlet port of the Multi Arm-Evac II and secure it with the hose clamp (provided). Connect the other end of the flex hose to the inlet of the articulated arm.
 - 5) If only one inlet port on the Multi Arm-Evac II is used make sure the unused inlet port has its cap in place.
 - 6) Repeat steps 1 through 4 if installing a second Articulated Extraction Arm.

Important

If the torsion spring is located properly, the extraction arm will support its own weight without over-tightening the thumbscrews. Otherwise, the arm will fall onto the tabletop.

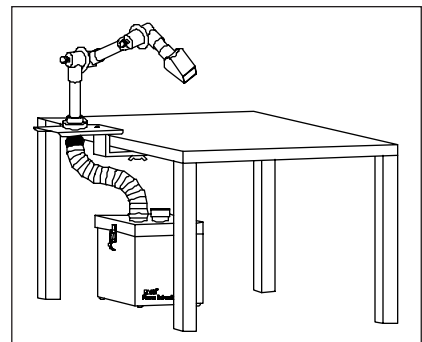

Connecting the Laminar Flow Endpiece with Bench Mounting Bracket

- 1) Place the Laminar Flow Endpiece with Bench Mounting Bracket in a convenient location on the tabletop.
- 2) Connect one end of the flexible hose (provided) to an inlet port on the Multi Arm-Evac II and the other end to the inlet port on the Laminar Flow Endpiece with Bench Mounting Bracket.
- 3) Secure the flexible hose to the Multi Arm-Evac II inlet port and the Laminar Flow Endpiece with Bench Mounting Bracket with the hose clamps (provided).
- 4) Ensure proper orientation of the Laminar Flow Endpiece with Bench Mounting Bracket for maximum extraction capability.
- 5) The Bench Mounting Bracket can be secured to the tabletop by installing a screw (not provided) through the hole in the base plate.
- 6) Make sure the inlet cap covers the unused inlet port if only one accessory is being used.

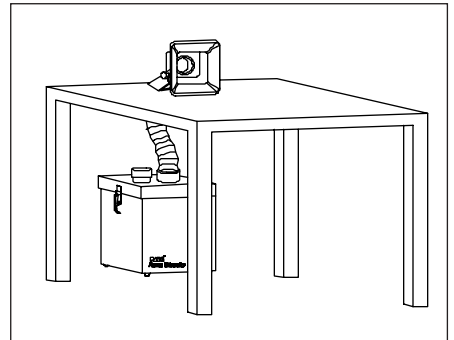

Connecting the Fume Cabinet

- 1) Place the Fume Cabinet in a convenient location on the tabletop.
- 2) Connect one end of the flexible hose to an inlet port on the Multi Arm-Evac II and the other end to the inlet port on the Fume Cabinet.
- 3) Secure the flexible hose to the inlet port and the Fume Cabinet with the hose clamps (provided).
- 4) Ensure proper orientation of the Fume Cabinet for maximum extraction capability.
- 5) Make sure the inlet cap covers the unused inlet port.

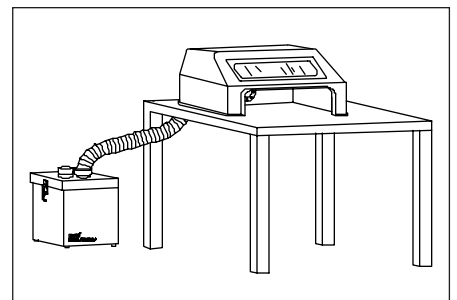

Note: Only one Fume Cabinet may be connected to a Multi Arm-Evac II.

OPERATION

OPERATION

The following information provides the user with the operating instruction for normal use.

Procedure

- 1) Turn on the Multi Arm-Evac II.
- 2) Position the Multi Arm-Evac II accessory in a convenient and effective extraction location.

General Tips

- Before opening the Multi Arm-Evac II, turn off the power source.
- Protect the Multi Arm-Evac II and accessories from dampness.
- Do not extract water vapor or steam.
- The Multi Arm-Evac II must not be used without filters. Impurities in the extracted air could damage the motor pump.
- Do not allow the Multi Arm-Evac II or ducting hoses to become blocked.
- Do not extract corrosive compounds without checking with PACE.

Fuses

The Multi Arm-Evac II comes standard with a 3.15 amp fuse for 8888-0815 (230 volt) or an 8 amp fuse for 8888-0825 (110 volt). Replacement Fuses for 8888-0815 are available as P/N 8884-9966-P5 and for 8888-0825 as P/N 8884-9961-P5, in packages of 5 fuses.

The fuse is located in a sliding tray on the back side of the Multi Arm-Evac II, just below the power receptacle. Each Multi Arm-Evac II is supplied with one replacement fuse, also located in the sliding tray.

MULTI ARM-EVAC II

Pre-Filter

The pre-filter removes coarse particles from the air. In general, the pre-filter must be changed on a monthly basis. However, depending on your particular process, the filter may need to be changed more or less frequently. A visual inspection on a weekly basis is recommended.

Replacing the Pre-Filter

- 1) Remove the filter access cover.
- 2) Remove the old pre-filter.
- 3) Install a new Pre-Filter. Make sure that the blue side of the filter faces up.
- 4) Replace the filter access cover.
- 5) Dispose of used Pre-Filter properly.

General Purpose Filter and Cleanroom Filter

General Purpose Filters and Cleanroom Filter remove particulates from the air and capture noxious odors and gases. In general, the General Purpose and Cleanroom Filters must be changed every 9 to 12 months. However, depending on your particular process, they may need to be changed more or less frequently.

Replacing the General Purpose and Cleanroom Filter Cartridges

- 1) Remove the filter access cover.
- 2) Remove the old filter cartridge.
- 3) Install new filter cartridge.
- 4) Install a new Pre-Filter. Make sure that the blue side of the filter faces up.
- 5) Replace filter access cover.
- 6) Dispose of old filter cartridge properly.

Important

BESURE the new filter cartridge is installed with the airflow arrow pointing downward.

Adhesives and Foam Particulate Filters

Replacing the Adhesives and Foam Particulate Cartridges

- 1) Remove the filter access cover.
- 2) Remove the old filter cartridge.

MAINTENANCE & REPLACEMENT PARTS

- 3) Install new filter cartridge.
- 4) Install a new Pre-Filter. Make sure that the blue side of the filter faces up.
- 5) Replace filter access cover.
- 6) Dispose of old filter cartridge properly.

Warning

Do not attempt to clean the pre-filters or HEPA filters for reuse. Cleaning the filters will severely damage the filter media and, consequently, the filter's performance. This will result in unfiltered, contaminated air being returned to the working environment. Unfiltered air can also damage the motor pump.

Motor

Fume Extractor Motors are maintenance-free, brushless single inlet fans which do not require routine maintenance. It is important that fume extractor filters are changed on a regular basis to protect the motor impellers from pollutants.

Multi Arm-Evac II Accessories

Monthly cleaning of the Multi Arm-Evac II extraction accessories is recommended. Multi Arm-Evac II accessories should be cleaned with a non-aggressive cleaning solvent or detergent only. Make sure the Multi Arm-Evac II accessories are completely dry before reuse.

REPLACEMENT FILTERS

Multi Arm-Evac II Filter Cartridges

| <u>Description</u> | <u>Part Number</u> |
|----------------------------------|--------------------|
| Pre-Filter (Pack of 5) | 8883-0111-P5 |
| General Purpose Filter Cartridge | 8883-0931 |
| Adhesives Filter Cartridge | 8883-0951 |
| Cleanroom Filter Cartridge | 8883-0921 |
| Economy Foam Filter | 8883-0871 |

Table 2: Replacement Filters

ACCESSORIES

PACE Flex Arm (P/N 8886-0365)

- 750mm (30") long x 75mm (3") diameter stay-put flex arm
- Fume collection hood
- Constructed of interlocked Polypropylene
- Optional Bench Mounting Kit (P/N 8886-0363)

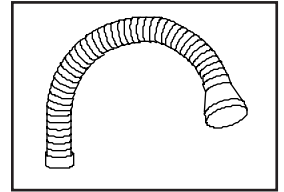

PACE Stay-Put Flex Tube (P/N 8886-0752)

- 750mm (30") long x 75mm (3") diameter stay-put flex arm
- Constructed of interlocked Polypropylene
- Can be used with any of three collection endpieces.
- Optional Bench Mounting Kit (P/N 8886-0363)

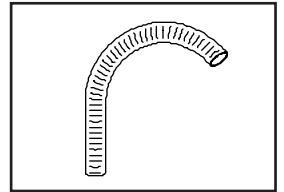

PACE Endpieces for Stay-Put Flex Tube



Suction Hood
P/N 8886-0930
For Omni-Directional
Air Flow



Fume Scoop
P/N 8886-0937
For Focused, Directional Air Flow



Laminar Flow Endpiece
P/N 8886-0938
Superior Wide Area Laminar Flow
Great for Work on Elevated Board Holders

PACE 45mm (1.75") Static Safe Metal Flex Arm (P/N 8886-0369)

- Bench-Mounted
- Static-Safe
- Includes Fume Scoop
- 1 m (40") long
- Optional Bench Mounting Bracket, (P/N 8886-1121)

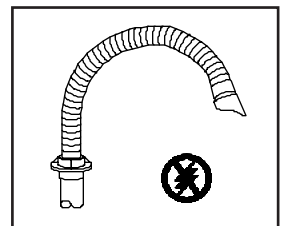

ACCESSORIES

ACCESSORIES

PACE Laminar Flow Endpiece with Bench Mounting Bracket (P/N 8886-0939)

- 230mm (9") high x 230mm (9") wide
- Provides Laminar Flow
- Static-Safe
- Supplied with 2.5 m (8') of 75mm (3") diameter flexible hose

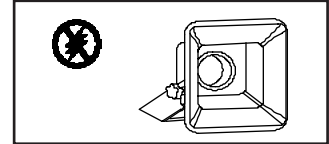

PACE Plenum (P/N 8886-0366)

- 18 gauge steel
- Overall dimensions 460mm (18") x 130mm (5") x 130mm (5")
- Static-Safe
- Supplied with 2.5 m (8') of 75mm (3") diameter flexible hose

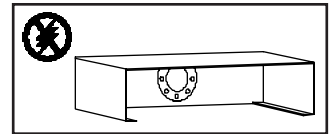

PACE Fume Cabinet (P/N 8886-0711)

- Polycarbonate construction
- Tempered glass vision panel
- Overall dimensions: 690mm (27") x 490mm (19.5") x 360mm (14")
- Front Opening: 510mm (20") x 140mm (5 1/2")
- Supplied with 2.5m (8') of 75mm (3") diameter flexible hose

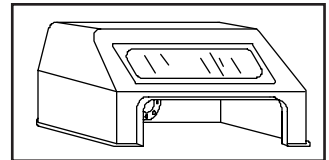

PACE 2-Section Articulated Arm

- 65 mm (2.5") P/N 8886-0650 or 50mm (2") diameter P/N 8886-0158 Bench-Mounted
- Static-Safe
- Uses Articulated Arm nozzles and endpieces (see pg. 23)
- Optional Bench Mounting Bracket
- 65mm (2.5") Arm P/N 8886-0662, 50mm (2") Arm P/N 8886-1121
- Requires 2.5 m (8') long 75mm (3") diameter flexible hose for 65mm (2.5") Arm P/N 8882-0755, 50mm (2") Arm P/N 8886-0299 with 50mm (2") reducer

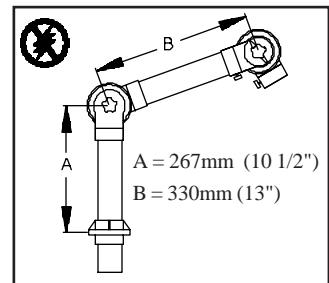

PACE 3-Section Articulated Arm (P/N 8886-0652)

- 65 mm (2.5") diameter, Bench-Mounted
- Static-Safe
- Uses Articulated Arm nozzles and endpieces (see pg. 23)
- Optional Bench Mounting Bracket (P/N 8886-0662)
- Requires (P/N 8882-0755)
2.5 m (8') of 75mm (3") diameter flexible hose

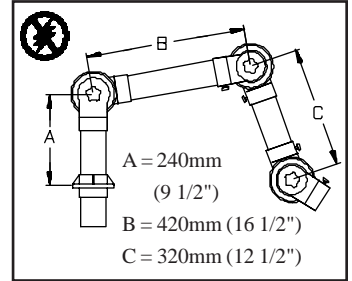

PACE Wall Mounted Articulated Arm (P/N 8886-0654)

- 65 mm (2.5") diameter, Wall-Mounted
- Static-Safe
- Uses Articulated Arm nozzles and endpieces (see pg. 23)
- Requires Wall Mounting Bracket (P/N 8886-0664)
- Requires (P/N 8882-0755)
2.5 m (8') of 75mm (3") diameter flexible hose

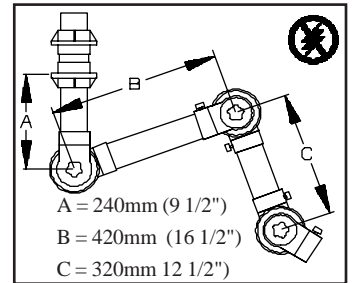

Bench Mounting Kit for PACE Flex Arm (P/N 8886-0363)

- Includes bench mounting bracket and 2.5 m (8') of 75mm (3") flex hose.

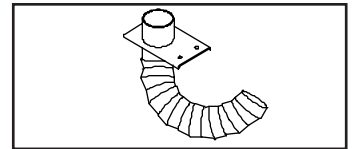

Expansion Kit for 45mm (1.75mm) Static-Safe Metal Flex Arm (P/N 8882-0692)

- Includes one 75mm (3") diameter "T", 1m (3 ft.) of 75mm (3") flexible hose, and 2.5m (8 ft.) of 75mm (3") diameter flexible hose with 75mm (3") to 50mm (2") reducer
- Required to connect more than two 45mm (1.75") Static-Safe Metal Flex Arms to the Multi Arm-Evac II

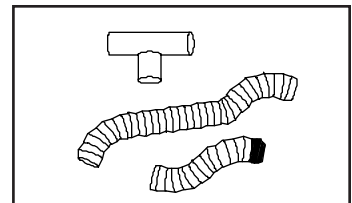

ACCESORIES

Multi Arm-Evac II Silencer (P/N 8885-0820)

- For applications where the Multi Arm-Evac II will be operating in a setting with low background noise levels. Silencer reduces sound levels nearly in half.
- 370mm (15") H x 135mm (5.5") W x 110mm (4.5") D

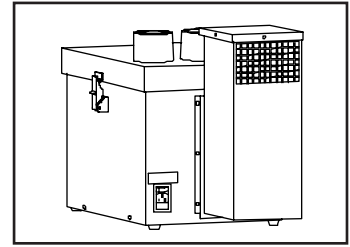

*Silencer shown with Multi Arm-Evac II

Multi Arm-Evac II Mobile Stand (P/N 8885-0152)

- Increases Portability
- PACE Posi-Stop locking Casters
- Installs in Seconds
- 70mm (2.75") H x 285mm (11.2") W x 285mm (11.2") D

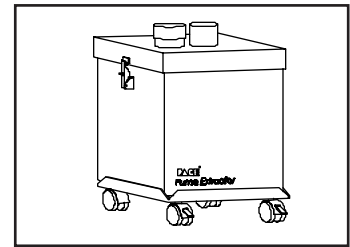

*Mobile Stand shown with Multi Arm-Evac II

FILTER OPTIONS

The Multi Arm-Evac II comes standard with the General Purpose filter consisting of a HEPA filter and a Gas filter. Three other filter options are also available.

- 1. General Purpose Filter (P/N 8883-0931):** Comprised of 2.8 m² (30 ft²) of HEPA filter media and 450 g (1 lb.) of gas blend media. Typical applications are:

| | |
|-----------------|----------------------------------|
| Soldering | Laser Cutting/Laser Marking |
| Pharmaceuticals | Jewelry Manufacturing and Repair |
- 2. Optional Adhesives Filter (P/N 8883-0951):** Blend of Adsorptive and Chemisorptive media. Comprised of 1.8 kg (4 lbs.) of gas filter media. Typical applications are:

| | |
|-------------------------------|-------------------------|
| Benchtop Adhesives Procedures | Circuit Board Cleaning |
| Gluing Applications | Laboratory Applications |
- 3. Optional Cleanroom Filter (P/N 8883-0921):** Comprised of 2.8 m² (30 ft²) of HEPA filter media and 450 g (1 lb.) of bonded activated carbon. Meets Class 100 cleanroom requirements. Typical applications: Fine particulate and gas removal in designated Cleanroom environments.
- 4. Optional Economy Foam Filter (P/N 8883-0871):** Carbon-Impregnated Reticulated Foam Media. Designed for coarse particle capture. Typical applications:

| | |
|---|-----------------------|
| Sanding Operations | Grinding Applications |
| Benchtop Machining and Prototyping Operations | |

ARTICULATED ARMS & ACCESSORIES







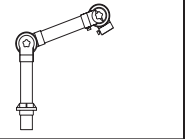

| | | |
|--|--|---|
|  | 2-Section Articulated Extraction Arm 65mm (2.5") P/N 8886-0650 Requires Flex Hose (P/N 8882-0755) and optional Endpiece, See Figure 5. |  |
|  | 2-Section Articulated Extraction Arm 50mm (2") P/N 8886-0158 Requires Flex Hose with 50mm (2") reducer (P/N 8886-0299) and optional Endpiece, See Figure 5. |  |
|  | 3-Section Articulated Extraction Arm 65mm (2.5") P/N 8886-0652 Requires Flex Hose (P/N 8882-0755) and optional Endpiece, See Figure 5. |  |
|  | Wall Mounted Articulated Extraction Arm 65mm (2.5") P/N 8886-0654 Requires Flex Hose (P/N 8882-0755), Wall Mounting Bracket (P/N 8886-0664) and optional Endpiece, See Figure 5. |  |
|  | 75mm (3") diameter Flex Hose, 2.5 m (8') in length P/N 8882-0755 Available as static-safe P/N 8882-0955 | |
|  | 75mm (3") diameter Flex Hose, 2.5m (8') in length with 50mm (2") reducer. P/N 8886-0299 | |

Figure 4: Multi Arm-Evac II - Articulated Arms

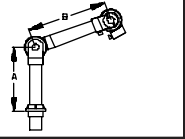

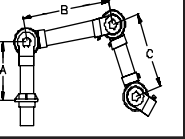

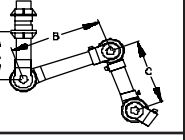

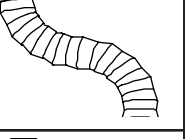
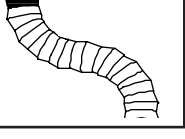

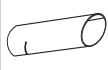

| | | | | |
|---|---|---|---|---|
|  | Suction Tube P/N 8886-0660 for 65mm (2.5") Arm 210mm (8.5") Long P/N 8886-1511 for 50mm (2") Arm 210mm (8.5") Long |  | Suction Nozzle P/N 8886-0315 100mm (4") Wide *For 50mm (2") Arm Only |  |
|  | Extraction Canopy P/N 8886-0656 for 65mm (2.5") Arm 254mm x 392mm (10" x 16") P/N 8886-0341 for 50mm (2") Arm 238mm x 282mm (9.75" x 11.5") | | Suction Nozzle P/N 8886-0325 200mm (8") Wide *For 50mm (2") Arm Only |  |
|  | Suction Hood P/N 8886-0658 for 65mm (2.5") Arm 200mm (8") Diameter P/N 8886-0351 for 50mm (2") Arm 200mm (8") Diameter |  | Suction Nozzle P/N 8886-0335 300mm (12") Wide *For 50mm (2") Arm Only |  |
|  | Bench Mounting Bracket P/N 8886-0662 for 65mm (2.5") Arm P/N 8886-1121 for 50mm (2") Arm | | Wall Mounting Bracket P/N 8886-0664 for 65mm (2.5") Arm |  |

Figure 5: Endpieces and Mounting Brackets for Articulated Arms



LIMITED WARRANTY

PACE warrants to the first user that this equipment will be free of defects in materials and workmanship for a period of one (1) year from the date of receipt by such user.

This warranty does not cover repair or replacement required as a result of misuse, mishandling or improper storage. Failure to perform recommended routine maintenance, alterations or repairs made other than in accordance with PACE's directions, or removal or alteration of identification plates in any way will void this warranty. This warranty is available only to the first user, but the exclusions and limitations herein apply to all persons and entities.

This warranty does not apply to consumable items such as tips, filter elements, hoses, collection chambers, etc., except that heaters are normally warranted for a period of six (6) months from the date of receipt by the first user.

PACE MAKES NO OTHER WARRANTY, EXPRESS OR IMPLIED, AND MAKES NO WARRANTY OF MERCHANTABILITY OR FITNESS FOR A PARTICULAR PURPOSE.

PACE will, at its option, repair or replace any defective equipment or parts at its facility or other location approved by it at no charge to user, or provide parts without charge for installation by the user in the field at user's expense and risk. User will be responsible for all costs of shipping equipment to PACE or other location for warranty service.

EXCEPT FOR THE REMEDY ABOVE DESCRIBED, UNLESS OTHERWISE REQUIRED BY APPLICABLE LAW, PACE WILL HAVE NO OTHER OBLIGATION WITH REGARD TO ANY BREACH OF WARRANTY OR OTHER CLAIM WITH RESPECT TO THE EQUIPMENT, OR LIABILITY FOR ANY DIRECT, INDIRECT, CONSEQUENTIAL, OR INCIDENTAL LOSS OR DAMAGE CAUSED BY OR OCCURRING IN CONNECTION WITH ANY OF THE EQUIPMENT.

To obtain warranty service, contact the appropriate PACE company listed below or your local Authorized PACE Distributor to determine if return of any item is required or if repairs can be made by the user in the field:

PACE, INCORPORATED 9893 Brewers Court Laurel, Maryland 20723
Telephone: (301) 490-9860 WARRANTY SERVICE FAX: (301) 604-9215

PACE EUROPE LIMITED Sherbourne House Sherbourne Drive Tilbrook Milton Keynes
Buckinghamshire England MK7 8HX Telephone: (44) 01908 277 666 WARRANTY SERVICE FAX: (44) 01908 277 777

Do not return defective parts or equipment to PACE or your local Authorized PACE Distributor without obtaining prior authorization.

Any warranty or other claim with respect to the equipment must be made in writing delivered to PACE (or your local Authorized PACE Distributor outside the U.S.) within a reasonable time of the expiration date of this warranty with sufficient evidence of purchase and date of receipt, otherwise user's rights under this warranty shall be deemed waived.